

OPTIONAL  
CRANK/  
HANDLE  
AVAILABLE  
CALL  
FOR

# THE ORIGINAL KAGAN RING ROLLER

ENLARGES STONE SET RINGS IN JUST MINUTES

## INSTRUCTION SHEET

### STEP ONE

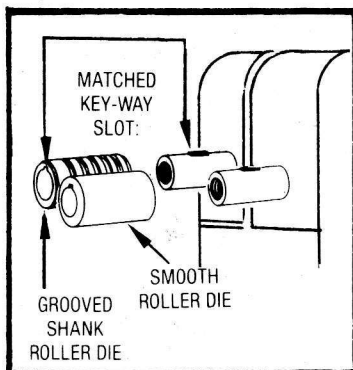

- Mount Ring Roller to a work bench or equal.
- Select GROOVED ROLLER to match the shape of the ring's shank. And, a PLAIN ROLLER to fit the ring's core.
- Place your chosen rollers. (A smooth one to the front and the grooved one to the rear.) Line up the key-way's tongue and groove for a perfect fit.

### STEP TWO

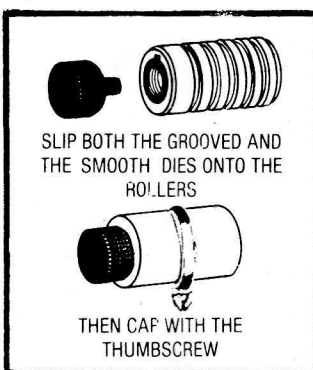
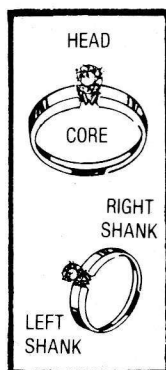

- Cap each with a THUMB SCREW.
- Turn Clamp Knob No. 1 to the LEFT to separate rollers. Place ring on the SMOOTH ROLLER with STONE HANGING DOWN (see illustration above). Adjust the ring's shank, between the rollers and turn Knob No. 1 to the RIGHT TO TIGHTEN. The ring must fit snugly.

### STEP THREE

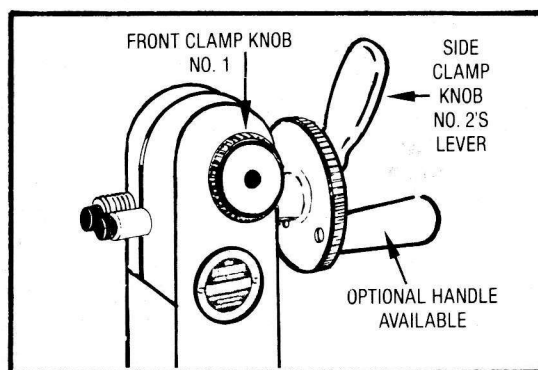

- TURN SIDE KNOB NO. 2 until the head of the ring rotates to the top of the rollers. GO SLOW! Then, IN REVERSE, return the ring to its original position, with its head hanging straight down. This increases the diameter of one side of the ring's shank only.
- Turn FRONT KNOB NO. 1 to the left, and remove the ring. Reverse it on the smooth die, as before, with its head hanging down. Enlarging both sides of the ring's shank will make it even and balanced. Check the fit with the customer often.

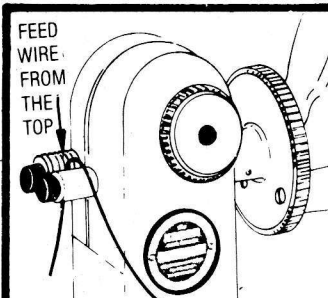

### MINIATURE ROLLING MILL

- Mount Ring Roller to a work bench or equal.
- Turn CLAMP KNOB NO. 1 to the left to separate rollers. Then, from the top, feed gold, silver or copper wire into a desired die-shape. Turn FRONT CLAMP NO. 1 to the right for a snug fit.
- Turn SIDE CLAMP NO. 2 SLOWLY TO THE RIGHT. Exert EVEN pressure for a smooth, clean job. For other shapes turn the wire over and feed through a second time.

### OPTIONAL HANDLE AVAILABLE

(Write or call your local distributor for details)

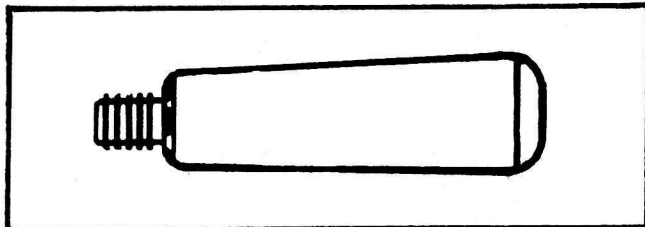

If you are ordering a KAGAN RING ROLLER FOR THE FIRST TIME, specify the optional "crank handle", at a small additional charge.

ROLLER and want the optional crank handle modification, take it to your local Kagan Distributor or call the factory direct for the Kagan Rep. nearest you. Installation takes about two weeks turn-around time.

If you own a KAGAN RING

FOR AN IMMEDIATE RESPONSE CALL FACTORY DIRECT AT (818) 896-8370

**J. J. KAGAN CO., INC.,**  
12734 BRANFORD STREET  
ARLETA, CALIFORNIA 91331

